

A photograph of two men in a server room. The man on the left is wearing a white shirt and holding a smartphone, gesturing with his hand. The man on the right is wearing a blue and white checkered shirt and glasses, holding a stack of papers. They are standing in front of server racks with blue lighting. In the top left corner, there is a white box containing the Siemens logo and tagline.

SIEMENS

Ingenuity for life

Miniature circuit-breaker versus electronic selectivity module

Selective monitoring of 24 V DC load circuits

In modern plant and machine construction all 24 V DC loads – whether rugged electro-mechanical loads or highly sensitive electronics – are supplied by a single, common, stabilized switch mode power supply. To ensure that a fault in one load does not bring the complete plant to a halt, the 24 V DC power supply circuit is divided into separate branches and selectively protected. Miniature circuit-breakers (MCBs) are often used for this purpose. In many cases, however, they do not offer reliable protection. Conversely, the electronic selectivity module monitors the 24 V DC branches safely and ensures



all-electronics.de
ENTWICKLUNG. FERTIGUNG. AUTOMATISIERUNG



Entdecken Sie weitere interessante Artikel und News zum Thema auf [all-electronics.de](https://www.all-electronics.de)!

Hier klicken & informieren!



Contents

3	Switched-mode power supplies protect themselves with electronic output current limiting
3	The typical behavior of miniature circuit-breakers
4	The problem with modern power supplies and conventional miniature circuit-breakers
4	Oversizing is an inadequate solution approach
4	Specially matched disconnection characteristics as optimal solution
4	Extensive functionality assures a targeted fault localization
5	Additional benefits during operation and commissioning
6	Application range of miniature circuit breakers and selectivity module

Miniature circuit breaker versus electronic selectivity module

Switched-mode power supplies protect themselves with electronic output current limiting

To provide power to the 24 V DC level of automated plants, primary switched-mode power supplies have long ago gained widespread acceptance and replaced the unregulated transformer power supply. In most cases, however, the distribution of the 24 V feed among multiple load groups and their protection are still handled by conventional miniature circuit-breakers. The internals of switching power supplies are dimensioned for a specific nominal power output. To protect the devices against damage from overloading, the output current is electronically limited. The current limiting normally starts at 1.1 to 1.5 times the nominal value. This limited maximum current also has an effect on the tripping response of miniature circuit-breakers.

The typical behavior of miniature circuit-breakers

The function of miniature circuit-breakers is the protection of wires against thermal damage to the insulation from too high a current. The tripping characteristics are thus matched to the current voltage characteristics of the wires. Looking at the various current-time characteristics of MCBs, two general tripping ranges can be distinguished resulting from two different disconnection mechanisms. In the range of small overcurrents, a time-delayed thermal tripping occurs through a bimetal. The duration until the tripping depends on the level of the overcurrent and can range from minutes to hours in the case of small overcurrent. The disconnection in the case of larger overcurrents (electrical shorts), on the other hand, is tripped electromagnetically without a delay. Here, the immediate tripping takes place within milliseconds by means of an electromagnet. So that the electromagnetic tripping of the MCB does not already respond at the normal operational starting current surges caused by the connected loads, different sensitivities exist, which are reflected in the tripping characteristics "A" to "D". In all cases, however, a multiple of the nominal current is required for the MCB to trip rapidly. If, for instance, a miniature circuit-breaker of the common type C is considered, the electromagnetic instant tripping occurs at 5 to 10 times the nominal current; if operated with DC voltage, the limit current values increase by a factor of 1.4. For a safe configuration, 14 times the nominal current thus has to be taken into account to achieve the instant tripping required for the selectivity.

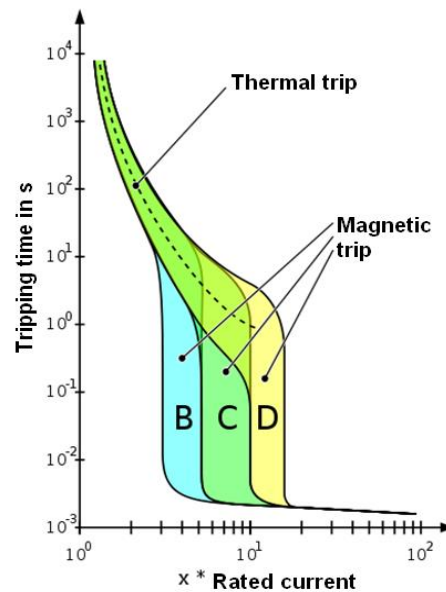

Fast tripping is important, because when the 24 V DC supply fails the intact branches are also undersupplied. Voltage interruptions of 20ms are already critical for the PLC and will cause the process to be interrupted or even to crash.

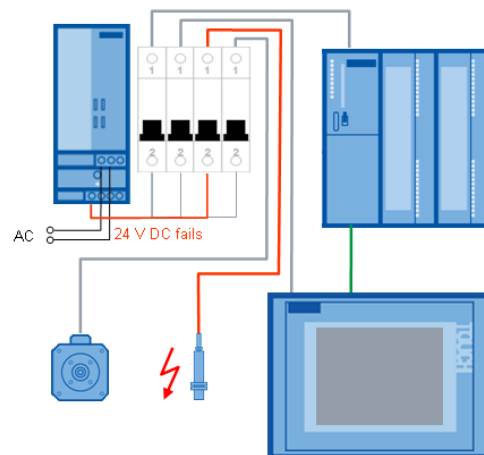

Application example with selective protection via miniature circuit-breaker:

In the event of an overload the switched-mode power supply limits the current and the miniature circuit-breaker does not trip sufficiently quickly. The 24 V DC supplies dip, all loads are undersupplied, and the PLC switches to the "Stop" state.

The problem with modern power supplies and conventional miniature circuit-breakers

The electronic current limiting of a power supply limits the output current during overloads to, for example, 1.5 times the nominal current. In the case of a 20 A device, this corresponds, for example, to a maximum current of 30 A. With this device, at best type C miniature circuit-breakers with a rated current up to 2 A can be safely and instantly tripped.

Oversizing is an inadequate solution approach

In the simplest case, a tripping of higher current-rated miniature circuit-breakers can be achieved by using a power supply with a higher power output. This, however, also requires more space and increases the costs. In some power supplies, a so-called "power boost" is integrated. Here, the device is capable of supplying – at least temporary – up to 6 times the nominal current.

But even this theoretically possible high output current is not the perfect solution for the problem – since in practice, ohmic resistances of the feed and return wires to and from the fault location often prevent this maximum current from flowing. Already at a loop impedance of only 0.4 Ohm (for a wire with a cross section of 1mm², this corresponds to a distance of only 11 m between power supply and load), a 20 A power supply –capable of briefly supplying 6 times the current (120 A) – can only drive 3 times the current (60A) through the short-circuit path. With this current, a type C miniature circuit-breaker with a nominal current of up to 4 A can then be safely tripped instantly. If, in addition to the pure lead resistance, the internal resistances of the power supply and miniature circuit-breaker are taken into account as well as the transfer resistances of the terminals and the actual short circuit, even this 60A will not be achieved and C4 will not trip immediately (see the application example on the next page). Although a higher current is flowing in the case of lower-ohmic faults, with which larger miniature circuit-breakers can be tripped as well, the parallel load branches see a voltage drop at least until the disconnection of the faulty path. This can disturb other electronic loads, if the disconnection does not take place within a few milliseconds. In the end, one has to realize that in the combination of switching power supply and miniature circuit-breaker, a selective disconnection of faulty load branches can only be achieved in special cases and with a lot of configuration effort.

Specially matched disconnection characteristics as optimal solution

The selectivity module is specifically matched to the output response of switched-mode power supplies and the 24 V DC branches to be supplied. With its special shutdown characteristic (see right) it responds to overcurrent in a faulty branch even if it only minimally exceeds the rated current. Long thin leads for which the short circuit current is limited by the high ohmic impedance can also be reliably protected in this way. This means that smaller conductor cross-sections are possible which result in savings especially over long distances. Apart from current monitoring in the

individual branches, the selectivity module also measures the output voltage from the power supply. However, should the power supply output voltage simultaneously drop below 20 V DC due to the total power being exceeded, all outputs carrying more than 100% of the individually set tripping current at that moment will immediately be disconnected. For all branches not overloaded, the 24 V DC supply is maintained without a disturbing drop – the operation of large plant sections can be continued.

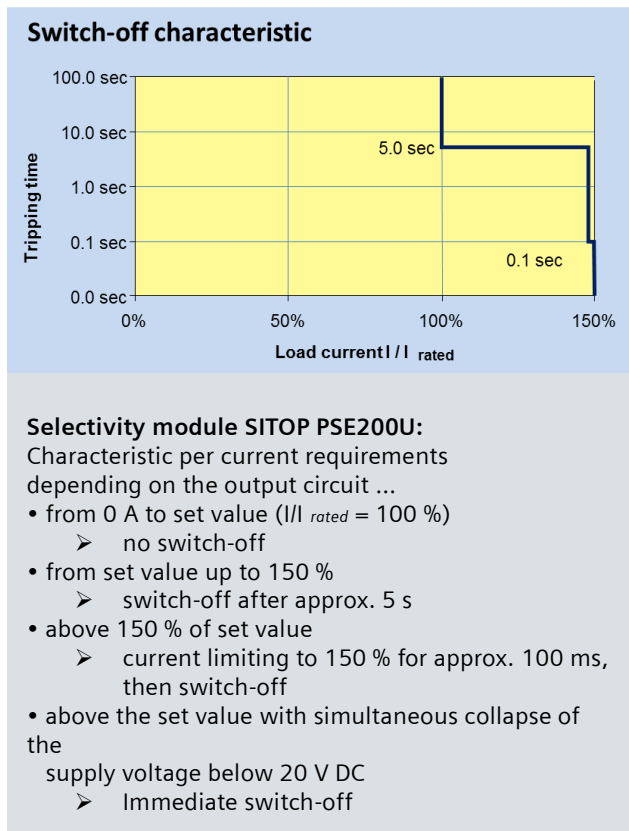

Extensive functionality assures a targeted fault localization

The tripping current of each output can be individually set with a potentiometer accessible from the front. This reduces the device variety and allows changes to be easily made even during commissioning. Two device versions with adjustment ranges from 0.5 to 3 A and 3 to 10 A are available for covering the widest possible current range. The status of the separate load circuits is indicated by one multi-colored LED per channel. In the event of a disconnection, the indicator changes from green to red. Depending on the device version, the fault is output by means of a common signaling contact or single-channel signaling. For single-channel signaling, the signaling output is to be connected to the PLC by only one standard digital input. The deactivated channel is signaled by a pulse pause protocol which is evaluated by a function block in the PLC (see below). Faults can be localized very quickly this way in a

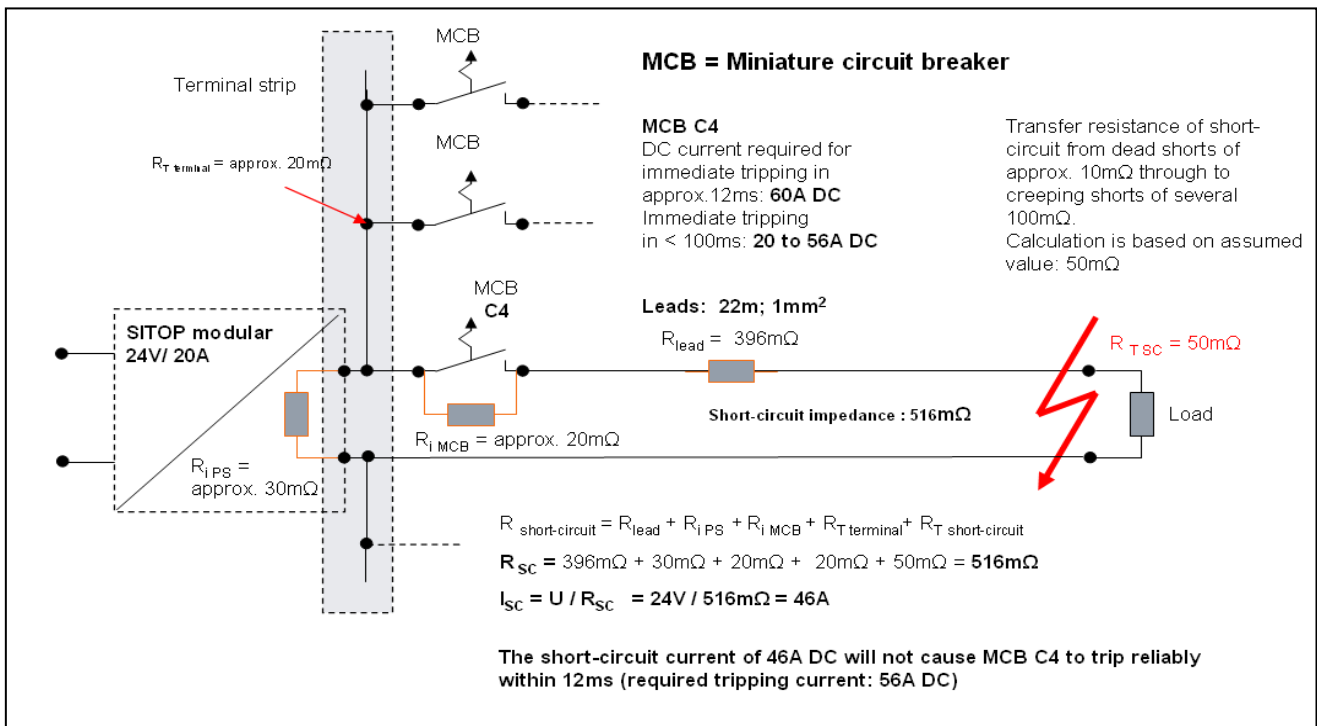

Application example with limited short circuit current

The short circuit current is reduced by various ohmic impedances which means that the current required for fast tripping of the miniature circuit-breaker cannot be achieved regardless of the output performance of the power supply.

higher-level control system or operator control and monitoring system which reduce downtimes even further.

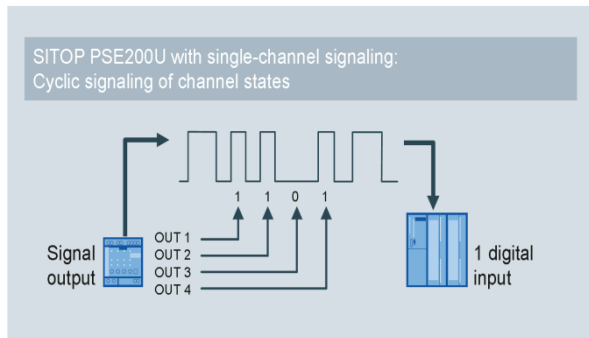

The SITOP PSE200U module with single-channel signaling outputs the status of the 4 channels cyclically by means of a serial code which can be read in by a digital input, e.g. of a PLC. Function blocks for SIMATIC S7-1500/1200/300/400 for STEP 7 and TIA Portal as well as for SIMOTION SCOUT and SIMOTION CPUs are available free of charge for the evaluation.
 Download of function blocks for SIMATIC S7:
<http://support.automation.siemens.com/WW/view/en/61450284>
 Function blocks for SIMOTION:
<http://support.automation.siemens.com/WW/view/en/82555461>

Additional benefits during operation and commissioning

If a fault only occurred temporarily during operation, the affected output can be reactivated via remote reset. The function can reduce travel times and possibly downtimes especially for remote parts of the plant. Individual branches

can be activated and deactivated manually by means of pushbuttons for support during commissioning and maintenance. A manually deactivated channel is indicated by a yellow LED. For safety reasons, the manual reset is not reversible via remote reset.

Another important function is the sequential switching on of the individual output channels. A delay time of 25 or 100 ms can be selected, which prevents a temporary overloading of the upstream power supply – and thus a disruption of the 24 V DC voltage – by not simultaneously switching on several connected loads. The reduced total inrush current may allow for the use of a smaller power supply.

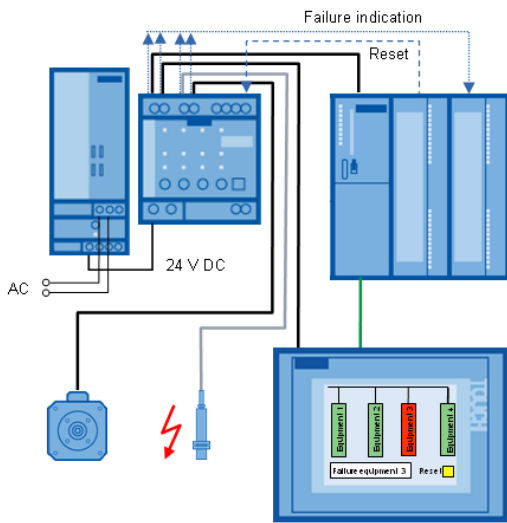

Application example with a standard power supply (for example, from the SITOP smart product line) and selectivity module SITOP PSE200U:

The selectivity module deactivates faulty channels at once in the event of imminent danger of a 24 V DC voltage drop. Critical loads like a PLC are supplied without interruption

Application range of miniature circuit breakers and selectivity module

Safety / Functionality	<p>Selectivity module and standard power supply</p> <ul style="list-style-type: none"> + Safe shutdown, even for low short-circuit current, e.g. due to long cables, small core cross-sections, creepage short-circuits + Uninterruptible operation of electronic loads such as PLCs, due to immediate disconnection of faulty branches when there is a risk of a voltage dip + Fault diagnosis via LEDs, common signaling contact or single channel signaling
	<p>MCB and power supply with power boost</p> <ul style="list-style-type: none"> + Rapid shutdown of faulty branches. Requires appropriate dimensioning of power supply, MCB, core cross-sections and wire length
	<p>Miniature circuit-breaker (MCB) and standard power supply</p> <p>Shutdown of faulty branches, longer tripping time and voltage dips possible; insensitive loads only, such as electro-mechanical systems, continue to operate</p>

Switched mode power supplies with miniature circuit-breakers offer a cost-efficient solution for loads that are not affected by voltage drops.

With a high overload capability of the power supply (Power Boost, for example, up to $6 \times I_{rated}$), tripping of the miniature circuit breaker can be accelerated. However, this combination does not guarantee adequate protection for critical loads in case of low short-circuit current.

The selectivity module offers higher configuration reliability under all conditions. Plus a standard switched-mode power supply is sufficient.

Conclusion:

With the selectivity module SITOP PSE200U, selectivity is reliably achieved in 24 V DC power supply circuits, it eliminates undesired reactions affecting the power supply resulting from short-circuits or overloads – since it monitors the current of each load circuit and reliably prevents a dropping of the supply voltage. The single-channel signaling already offers fault localization and a response from a central location. The channel-specific LED indicators in the control cabinet help you locate faults quickly, to prevent complete plant failures and to minimize partial failures to a very short period of time. Remote reset, manual activation and deactivation as well as sequential switching on of individual 24 V DC branches are additional benefits.

Siemens AG
 Process Industries and Drives
 P.P. Box 484
 90026 Nuremberg